

ORDINANCE NO. 4-1995

Offered by: Mr. Davis
Mr. Lyons

AN ORDINANCE AMENDING SECTIONS 1133.03, 1153.03, AND 1167.03 SETTING THE STANDARDS FOR PARKING AND LOADING REQUIREMENTS FOR RESIDENTIAL, COMMERCIAL AND INDUSTRIAL ZONING AREAS.

WHEREAS, this Council, upon recommendation of the Village Planning Consultant and Planning Commission, wishes to amend the standards for parking.

NOW, THEREFORE, BE IT ORDAINED by the Council of the Village of Richfield, State of Ohio:

- SECTION 1. That Section 1133.03 of the Planning and Zoning Code be amended to read according to the standards attached as exhibit "A".
- SECTION 2. That Section 1153.03 of the Planning and Zoning Code be amended to read according to the standards attached as exhibit "B".
- SECTION 3. That Section 1167.03 of the Planning and Zoning Code be amended to read according to the standards attached as exhibit "C".
- SECTION 4. That Sections 1133.03, 1153.03 and 1167.03 as they existed prior to the effective date of this Ordinance be, and the same hereby are, repealed.
- SECTION 5. This Ordinance shall take effect and be in force from and after the earliest period allowed by law.

Passed: 5-16-95

Patricia S. Healey

President of Council

[Signature]

Mayor

Dated: 5-16-95

ATTEST:

Clerk of Council

EXHIBIT "A"

CHAPTER 1133

RESIDENTIAL PARKING AND LOADING REQUIREMENTS

1133.03 (a) ***

1133.03 (b) amend to read:

(b) Parking Space: Off Street accessory parking areas shall provide parking spaces, each of which shall be not less than nine feet (9') wide and not less than twenty feet (20') long, exclusive of all driveways, aisles, ramps and turning spaces. An off street parking space for the Physically Handicapped shall be not less than thirteen feet (13') wide and not less than twenty feet (20') long exclusive of all driveways, aisles, ramps and turning spaces.

1133.03 (c) add a sentence to this paragraph as follows:

Parking areas shall be designed according to the following diagram: "STANDARDS FOR DESIGNING PARKING AREAS".

133.03 (c) STANDARDS FOR DESIGNING PARKING AREAS

45°

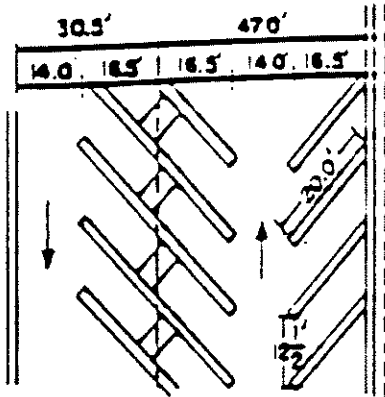

ONE WAY TRAFFIC

45°

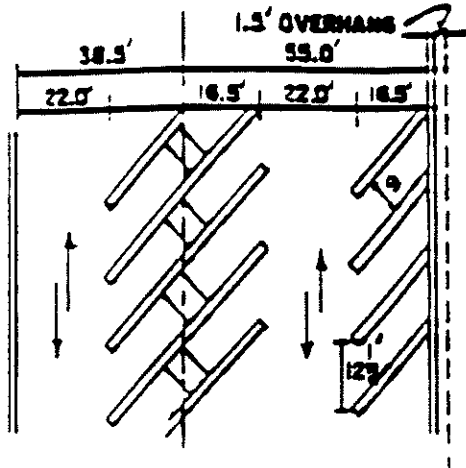

TWO WAY TRAFFIC

60°

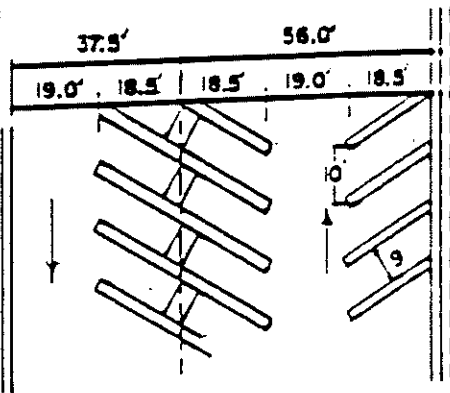

ONE WAY TRAFFIC

60°

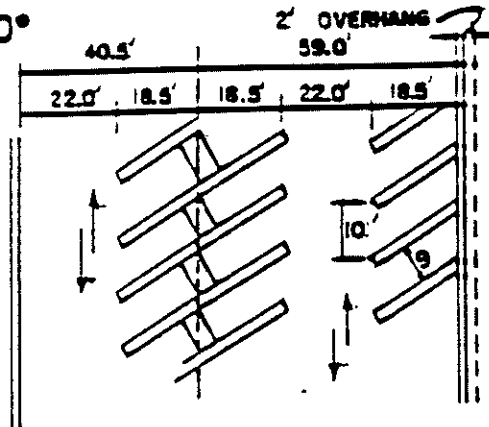

TWO WAY TRAFFIC

90°

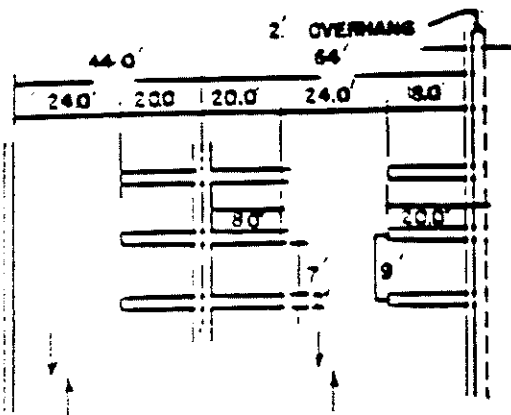

ONE OR TWO WAY TRAFFIC

1133.03 (d) Entrances and Exits

The above wording changed to "Driveways"

(d) Driveways

1. Driveways shall be located to minimize traffic congestion and avoid undue interference with pedestrian access at street intersections. Generally, there shall be not more than two driveways on to one street from each parcel of property. Minimum and maximum driveway widths shall be as follows:

Number of lanes in Driveway	Minimum Width of Driveway(ft)	Maximum Width of Driveway(ft)
One(a)	10	12
Two	20	24
Three	30	36
Four	40(b)	48(b)

- (a) Permitted where there are 10 or less parking spaces served provided there shall be two lanes having a minimum, width of not less than 20 feet from the pavement of the road for a distance of not less than 20 feet.
 - (b) Plus a minimum six foot island or traffic divider.
2. Curb cuts for parking area driveways shall have a radius of not less than ten feet (10') nor more than thirty feet (30').

1133.03 Add a new paragraph (k) "Parking Spaces for Physically Handicapped."

1133.03 (k) Parking Spaces for Physically Handicapped.

Parking Spaces for the Physically Handicapped shall be designated and may be used to compute the total number of spaces required. The number and location of the designated spaces shall be in compliance with the requirements of the Ohio Basic Building Code as follows:

<u>Total Number of Spaces in the Lot or Structure</u>	<u>Required Number of Accessible Spaces</u>
Up to 100	One space per 25 parking spaces
101 to 200	Four spaces plus one space per 50 parking spaces over 100
201 to 500	Six spaces plus one space per 75 parking spaces over 200
Over 500	Ten Spaces plus one space per 100 parking spaces over 500

All such handicapped parking spaces shall be designated by free-standing signs as provided for pursuant to the Ohio Manual of Uniform Traffic Control Devices, Type R-59-A and/or R-59-B.

Add a new paragraph (l) Striping and Traffic Control.

(l) Striping and Traffic Control

1. Any parking area with four or more off street parking spaces shall be striped and maintained in good condition to be clearly visible with lines four inches wide to indicate parking space limits.
2. Any off street parking area shall be marked or posted with such traffic control devices as may be determined necessary by the Police Chief for the protection of operators and pedestrians, including directional arrows, one way signs, no parking signs and fire lane signs.

EXHIBIT "B"

CHAPTER 1153

COMMERCIAL PARKING AND LOADING REQUIREMENTS

1153.03 (a) * * *

1153.03 (b) amend to read:

(b) Parking Space: Off Street accessory parking areas shall provide parking spaces, each of which shall be not less than nine feet (9') wide and not less than twenty feet (20') long, exclusive of all driveways, aisles, ramps and turning spaces. An off street parking space for the Physically Handicapped shall be not less than thirteen feet (13') wide and not less than twenty feet (20') long exclusive of all driveways, aisles, ramps and turning spaces.

1153.03 (c) add a sentence to this paragraph as follows:

Parking areas shall be designed according to the following diagram: "STANDARDS FOR DESIGNING PARKING AREAS".

1153.03(c) STANDARDS FOR DESIGNING PARKING AREAS

45°

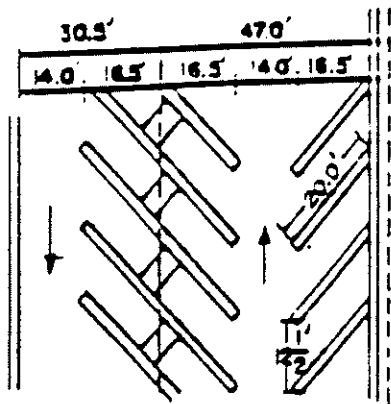

ONE WAY TRAFFIC

45°

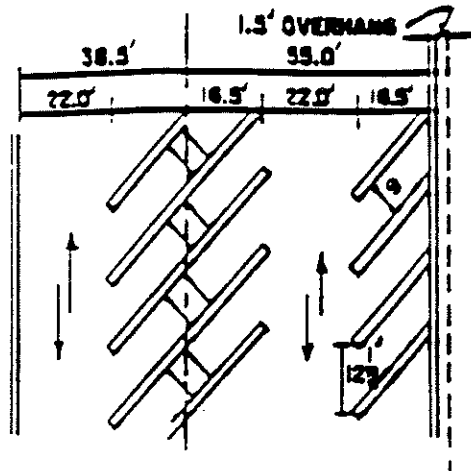

TWO WAY TRAFFIC

60°

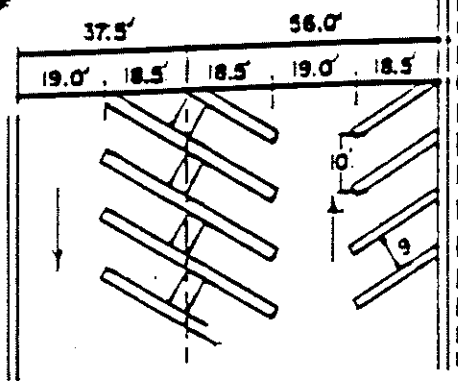

ONE WAY TRAFFIC

60°

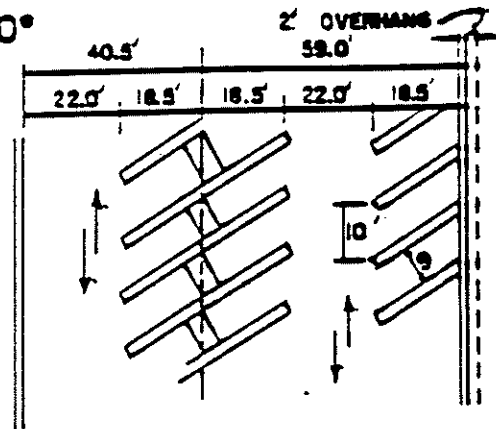

TWO WAY TRAFFIC

90°

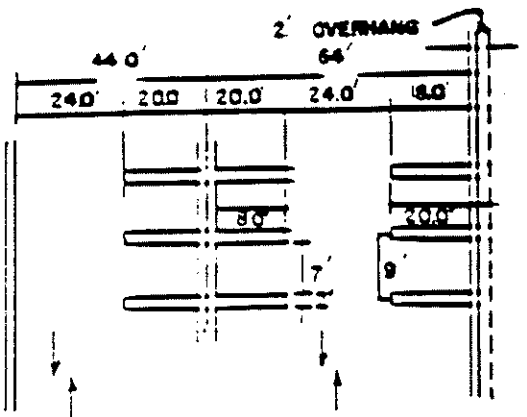

ONE OR TWO WAY TRAFFIC

1153.03 (d) Entrances and Exits

The above wording changed to "Driveways"

(d) Driveways

1. Driveways shall be located to minimize traffic congestion and avoid undue interference with pedestrian access at street intersections. Generally, there shall be not more than two driveways on to one street from each parcel of property. Minimum and maximum driveway widths shall be as follows:

Number of lanes in Driveway	Minimum Width of Driveway(ft)	Maximum Width of Driveway(ft)
One(a)	10	12
Two	20	24
Three	30	36
Four	40(b)	48(b)

- (a) Permitted where there are 10 or less parking spaces served provided there shall be two lanes having a minimum, width of not less than 20 feet from the pavement of the road for a distance of not less than 20 feet.
 - (b) Plus a minimum six foot island or traffic divider.
2. Curb cuts for parking area driveways shall have a radius of not less than ten feet (10') nor more than thirty feet (30') provided however that curb cuts for parking area driveways to be used by commercial vehicles shall have a radius of not less than forty five feet (45') nor more than sixty feet (60').

1153.03 (e) Yard Requirements

Rewrite the last sentence of this paragraph as follows:

Parking for commercial uses in the C-3 Commercial District and in the C-S Special Commercial District may be permitted in a portion of the required side or rear yard adjacent to a residential district but such parking shall not be less than three feet from the side or rear lot line provided the parking area is screened from the residential district by a solid fence or wall not less than five feet nor more than six feet tall.

1153.03 (f) Joint Use

add paragraph (4) as follows:

- (4) A commercial use located within the 'C-3' Commercial District or within the 'CS' Special Commercial District may be permitted to allocate not more than fifty percent of the required off street parking spaces to another existing parking area on another parcel within 500 feet of the property boundary provided the owner/occupant can demonstrate to the satisfaction of the Commission that the total number of parking spaces for both uses available during regular business hours shall be not less than required for the uses and further provided that the Commission shall receive a signed copy of a permanent easement agreed to by the owners/ occupants for such joint use of parking facilities.

1153.03(g) * * *

1153.03 Add a new paragraph (h) Parking Spaces for the Physically Handicapped.

1153.03 (h) Parking Spaces for Physically Handicapped.

Parking Spaces for the Physically Handicapped shall be designated and may be used to compute the total number of spaces required. The number and location of the designated spaces shall be in compliance with the requirements of the Ohio Basic Building Code as follows:

<u>Total Number of Spaces in the Lot or Structure</u>	<u>Required Number of Accessible Spaces</u>
Up to 100	One space per 25 parking spaces
101 to 200	Four spaces plus one space per 50 parking spaces over 100
201 to 500	Six spaces plus one space per 75 parking spaces over 200
Over 500	Ten Spaces plus one space per 100 parking spaces over 500

All such handicapped parking spaces shall be designated by free-standing signs as provided for pursuant to the Ohio Manual of Uniform Traffic Control Devices. Type R-59-A and/or R-59-B.

1153.03 Add a new paragraph (i) Striping and Traffic Control.

(i) Striping and Traffic Control

1. Any parking area with four or more off street parking spaces shall be striped and maintained in good condition to be clearly visible with lines four inches wide to indicate parking space limits.
2. Any off street parking area shall be marked or posted with such traffic control devices as may be determined necessary by the Police Chief for the protection of operators and pedestrians, including directional arrows, one way signs, no parking signs and fire lane signs.

EXHIBIT "C"

CHAPTER 1167

INDUSTRIAL PARKING AND LOADING REQUIREMENTS

1167.03 (a) * * *

1167.03 (b) amend to read:

(b) Parking Space: Off Street accessory parking areas shall provide parking spaces, each of which shall be not less than nine feet (9') wide and not less than twenty feet (20') long, exclusive of all driveways, aisles, ramps and turning spaces. An off street parking space for the Physically Handicapped shall be not less than thirteen feet (13') wide and not less than twenty feet (20') long exclusive of all driveways, aisles, ramps and turning spaces.

1167.03 (c) add a sentence to this paragraph as follows:

Parking areas shall be designed according to the following diagram: "STANDARDS FOR DESIGNING PARKING AREAS".

1167.0310 STANDARDS FOR DESIGNING PARKING AREAS

45°

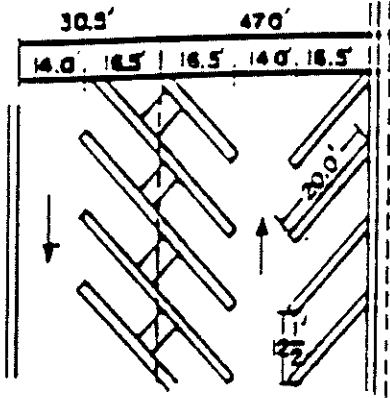

ONE WAY TRAFFIC

45°

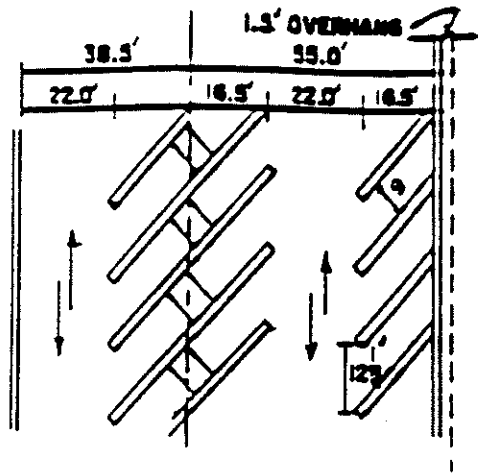

TWO WAY TRAFFIC

60°

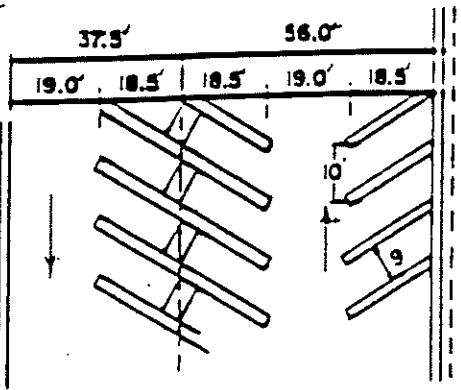

ONE WAY TRAFFIC

60°

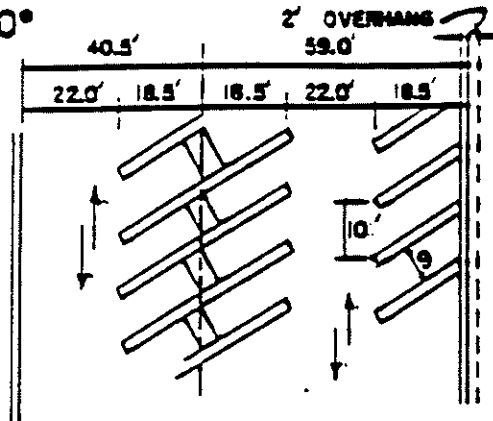

TWO WAY TRAFFIC

90°

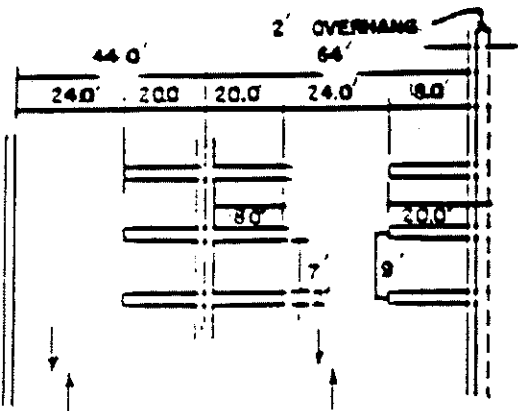

ONE OR TWO WAY TRAFFIC

1167.03 (d) Entrances and Exits

The above wording changed to "Driveways"

(d) Driveways

1. Driveways shall be located to minimize traffic congestion and avoid undue interference with pedestrian access at street intersections. Generally, there shall be not more than two driveways on to one street from each parcel of property. Minimum and maximum driveway widths shall be as follows:

Number of lanes in Driveway	Minimum Width of Driveway(ft)	Maximum Width of Driveway(ft)
One(a)	10	12
Two	20	24
Three	30	36
Four	40(b)	48(b)

- (a) Permitted where there are 10 or less parking spaces served provided there shall be two lanes having a minimum, width of not less than 20 feet from the pavement of the road for a distance of not less than 20 feet.
- (b) Plus a minimum six foot island or traffic divider.

2. Curb cuts for parking area driveways shall have a radius of not less than forty five feet (45') nor more than sixty feet (60').

1167.03 (e) * * *

1167.03 (f) thru (g) * * *

1167.03 Add a new paragraph (h) Parking Spaces for the Physically Handicapped.

1167.03 (h) Parking Spaces for Physically Handicapped.

Parking Spaces for the Physically Handicapped shall be designated and may be used to compute the total number of spaces required. The number and location of the designated spaces shall be in compliance with the requirements of the Ohio Basic Building Code as follows:

<u>Total Number of Spaces in the Lot or Structure</u>	<u>Required Number of Accessible Spaces</u>
Up to 100	One space per 25 parking spaces
101 to 200	Four spaces plus one space per 50 parking spaces over 100
201 to 500	Six spaces plus one space per 75 parking spaces over 200
Over 500	Ten Spaces plus one space per 100 parking spaces over 500

All such handicapped parking spaces shall be designated by free-standing signs as provided for pursuant to the Ohio Manual of Uniform Traffic Control Devices, Type R-59-A and/or R-59-B.

1167.03 Add a new paragraph (i) Striping and Traffic Control.

(i) Striping and Traffic Control

1. Any parking area with four or more off street parking spaces shall be striped and maintained in good condition to be clearly visible with lines four inches wide to indicate parking space limits.
2. Any off street parking area shall be marked or posted with such traffic control devices as may be determined necessary by the Police Chief for the protection of operators and pedestrians, including directional arrows, one way signs, no parking signs and fire lane signs.